



Schoolyard Breezes

Objective

- Students will be able to observe and measure the wind outdoors.

Procedure

1. Ask for students' ideas about wind and about how to observe wind activity. Help students narrow their observations to direction and speed. Tell students they are going to act as weather people and record and report on the wind in their schoolyard using a variety of simple wind tools that measure direction and speed. Tools will include a wind vane, wind direction indicator, pinwheel, anemometer, and a protractor wind speed indicator.

2. To measure wind speed, students will need to develop a scale to gauge the pinwheel and anemometer for calm, gentle, moderate, and strong categories (see **Wind Scale Chart** in "What the Wind Does for Me"). The protractor wind speed indicator has a scale but it may be too advanced for some students. Students might want to use the wind chimes they made in the **Wind Chime Rhapsody** in the activity What the Wind Does for Me.

3. Have a prototype of the weather instruments available for students to observe. Students should generate ideas about what they think each tool measures and why measuring that property of wind is important.

4. Take the class outside and review the direction orientations with students (north, south, east, and west). NOTE: To help younger students understand directions, you might want to orient them to a landmark in the schoolyard, such as a tree or a building.

5. Model the wind direction tools and the wind speed tools to the class. Introduce students to the **Wind Scale Chart**. It might be helpful to create student sheets to ensure that everyone is following the same method of recording (see **Schoolyard Breezes Recording Sheet**).

6. Divide the class into groups and assign each group to different locations around the schoolyard (four to five weather stations are recommended). Instruct each group to make a wind direction instrument and wind speed instrument at their location. Students can record their findings in the **Schoolyard Breezes Recording Sheet** and their **Energy Learning Logs**. Repeat the wind measurements daily throughout the week. If possible, do the measurements two to three times a day.

7. Discuss with students how wind is an example of a force that can push or pull. Have students describe how the force of the wind affected each of the measuring tools. Include discussion about how winds speed and direction affected each of the tools.

8. At the end of the week students should look back through the **Energy Learning Logs** and discuss their findings. Did they notice any patterns in the wind? Is it windier during certain times of the day or under certain weather conditions?

9. Once students have measured the wind patterns and speed around the schoolyard have them present to the class a mini weather report with the data they have gathered in their **Energy Learning Logs**. They can also diagram the schoolyard to note wind patterns according to their **Energy Learning Logs**.

Assessment

- Have students identify and construct various simple wind-measuring devices and accurately explain what wind property each instrument measures.
- Have students log simple wind measurements and report their findings to the class.
- Have students diagram the wind patterns around the schoolyard and think about where they could stand to either feel the wind or stay sheltered from it.

Summary:

Students build and use simple wind measurement instruments to record air movements in their schoolyard.

Grade Levels: (K-2) 3-4

Subject Areas: Language Arts, Mathematics, Earth and Physical Science, Environmental Literacy & Sustainability, Art, Social Studies

Setting: Various stations set up throughout the schoolyard

Time:

Preparation: 20 minutes
Activity: 50-minute period for each outdoor visit

Vocabulary: Anemometer, Force, Temperature, Thermal, Wind vane

Standards Addressed:

CC ELA: L.K.1.D, RI.3.3-4, SL.K.1&3-6, SL.1.1.B, SL.1.3-6, SL.2.1.A-C, SL.2.2&4&6, SL.3.1.D, SL.3.6, SL.4.1.C-D, SL.4.5, W.K.2&7-8, W.1.2, W.2-4.7, W.4.2.D

CC Math: MP5, MP6, MP7

NGSS: K-PS2-1, K-ESS2-1, 3-ESS2-1
SEP: Planning and Carrying Out Investigations, Analyzing and Interpreting Data, Constructing Explanations and Designing Solutions, Connections to Nature of Science, Scientific Investigations Use a Variety of Methods, Science Knowledge is Based on Empirical Evidence
DCI: PS2.A: Forces and Motion, PS3.C: Relationship Between Energy and Forces, ESS2.D: Weather and Climate, ETS1.A: Defining and Delimiting an Engineering Problem
CCC: Patterns, Cause and Effect, Connections to Engineering, Technology, and Applications of Science, Interdependence of Science, Engineering, and Technology, Influence of Engineering, Technology, and Science on Society and the Natural World, Connections to Nature of Science, Science is a Human Endeavor

EL&S: Connect: C1.A.i, C1.B.e, C1.C.e
Explore: EX2.A.e, EX3.B.e, EX4.A.i, EX5.B.e

Continued next page

Materials:

- **Wind Scale Chart**
- Material to construct wind instruments (see **Wind Instrument Construction**)
- **Energy Learning Logs** and writing implements
- **Schoolyard Breezes Recording Sheet** (optional – see example)
- Weather thermometer set up at each weather station (optional)
- Compass (optional)

Related KEEP Activities:

In “Waterwheels, Windmills, and Turbines” students construct simple turbines to investigate how the energy in wind power can be harnessed to do work. Available at keepprogram.org.

Extensions

Have students make a picto- or bar graph of their data.

Students can take other measurements, such as cloud cover and temperature, at the weather stations.

Have students watch the evening weather to determine if their readings are similar to the local meteorologist.

Have students use the measuring tools during different seasons and compare patterns.

Invite a local meteorologist to class to discuss wind patterns and wind-measuring devices.

Take a tour to a weather station or wind generator.

Discuss how early explorers and modern travelers use the wind to sail across bodies of water. Investigate different types of sails and have students make simple sailboats. Try similar investigations with air travel (gliders and hot air balloons).

Have students incorporate the diagrams, pictures, and data of wind speed in the schoolyard into their **Energy Flow Mural**.

Ask students if they have ever seen a bird soaring through the air. Ask them how the birds do this. Explain that wind is not only close to the ground but also high in the air, and teach a lesson on thermal air currents.

Wind Instrument Construction

Possible Wind Direction Tools:

wind vanes, wind direction indicators

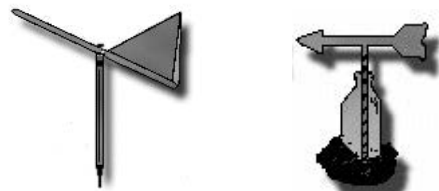

Possible Wind Speed Tools:

pinwheels, anemometers, and wind chimes (See **Wind Chime Rhapsody** in “What the Wind Does for Me”).

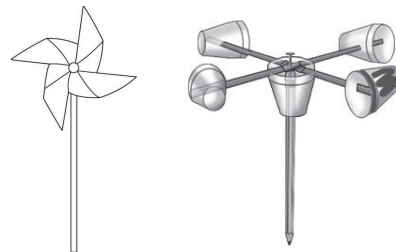

To measure wind speed, students will need to develop a scale to gauge for calm, gentle, moderate, and strong categories (see **Wind Scale Chart** in “What the Wind Does for Me”).

More advanced students might want to try the protractor wind speed indicator from the KEEP *Energy Education Activity Guide* (in the activity “Siting for Solar and Wind Energy”) available at keepprogram.org. NOTE: The wind scale can be adapted for young students by using calm, gentle, moderate, and strong to replace the numbers.

Wind instrument designs and instructions are found on pages 21-25. Many additional options can be found on the Internet.



Schoolyard Breezes Recording Sheet





Weather Station # _____ Measuring Tool _____

Date _____ Time _____

Diagram of Schoolyard and Weather Stations



N

	Circle One			
Wind Direction	N	S	E	W
Wind Speed	Calm	Gentle	Moderate	Strong
Temperature (optional)				
Cloud Cover (optional)				



Wind Instrument Construction

Pinwheel Wind Collector

Materials:

- A straight pin
- A square piece of construction paper (about 8.5" x 8.5")
- A sharpened pencil with an eraser
- Scissors

Procedure

Lay the square of paper flat on a table and draw a line diagonally from each corner to the opposite corner. Mark the center of the square where the two lines cross and punch a small hole through it with the pencil tip. Next, cut along each line, stopping about an inch from the hole in the center of the square. Take the straight pin and punch a hole in the top left corner of each of the four flaps. (No two holes should be next to each other.) Pick up a flap at a punched corner and carefully curve it over toward the center hole, securing it with the straight pin. Repeat this for the other flaps. When all four flaps are held by the straight pin, carefully lift the paper without letting the flaps unfurl. Lay the pencil flat on a table and carefully push the point of the straight pin into the side of the eraser.

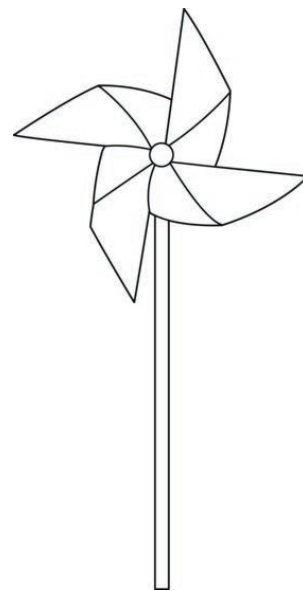

Now your pinwheel is complete and ready to go. Pick up the pinwheel near the pencil point and let it catch the wind. Notice that the pinwheel only spins when the wind hits its center.

You now have a simple wind collector. The pinwheel is an example of a horizontal-axis active wind collector. It must be pointed into the wind in order to spin.



Wind Instrument Construction

Anemometer

Materials:

- Five 3-ounce paper drinking cups
- Two straight plastic soda straws
- One straight pin
- Scissors
- Small stapler
- Sharp pencil with an eraser
- Paper punch



Procedure

Take four of the paper cups. Using the paper punch, punch one hole in each, about a half inch below the rim.

Take the fifth cup. Punch four equally spaced holes about a quarter inch below the rim. Then, using a pencil, punch a hole in the center of the bottom of the cup.

Take one of the one-hole cups and push a soda straw through the hole. Fold the end of the straw, and staple it to the side of the cup across from the hole. Repeat this procedure for another one-hole cup and the second straw.

Now slide one cup and straw assembly through two opposite holes in the cup with five holes. Push another one-hole cup onto the end of the straw just pushed through the five-hole cup. Bend the straw and staple it to the one-hole cup, making certain that the cup faces in the opposite direction from the first cup. Repeat this procedure using the other cup and straw assembly and the remaining one-hole cup.

Align the four cups so that their open ends face in the same direction (clockwise or counterclockwise) around the center cup. Push the straight pin through the two straws where they intersect. Push the eraser end of the pencil through the bottom hole in the center cup. Push the straight pin into the end of the pencil eraser as far as it will go. Your anemometer is ready to use.

Your anemometer is useful because it rotates at the same speed as the wind. This instrument is quite helpful in accurately determining wind speeds because it gives a direct measure of the speed of the wind. To find the wind speed, determine the number of revolutions per minute. Next calculate the circumference of the circle (in feet) made by the rotating paper cups. Multiply the revolutions per minute by the circumference of the circle (in feet per revolution), and you will have the velocity of the wind in feet per minute. The anemometer is an example of a vertical-axis wind collector. It need not be pointed into the wind to spin.



Wind Instrument Construction

Wind Direction Indicator

Materials:

- One straight plastic soda straw
- One piece of construction paper
- A pencil with an eraser tip
- One straight pin
- Stapler
- Scissors

Procedure

Cut one end off the piece of construction paper so that it is square. Fold one corner of the square over until it meets the opposite corner to form a large triangle. Crease the fold and open the paper. Cut along the fold to make two triangles. Fold one triangle in half once again and crease it along the fold. Next place an open edge of this folded triangle over the soda straw with the point toward the center of the straw and the other open edge at the end of the straw. Staple the tail to the straw. Next push the straight pin through the soda straw about one inch ahead of the front of the tail. Push the straight pin into the top of the eraser on the pencil. Your wind direction indicator is now ready to use.

Hold the wind direction indicator in the wind. It automatically turns around until the **tail of the straw points away from the wind and the tip points into the wind**. This instrument is useful in determining where the wind is coming from at any time and in noting variations during the day or from season to season. Hold your wind direction indicator in the wind and notice how often the wind direction changes.

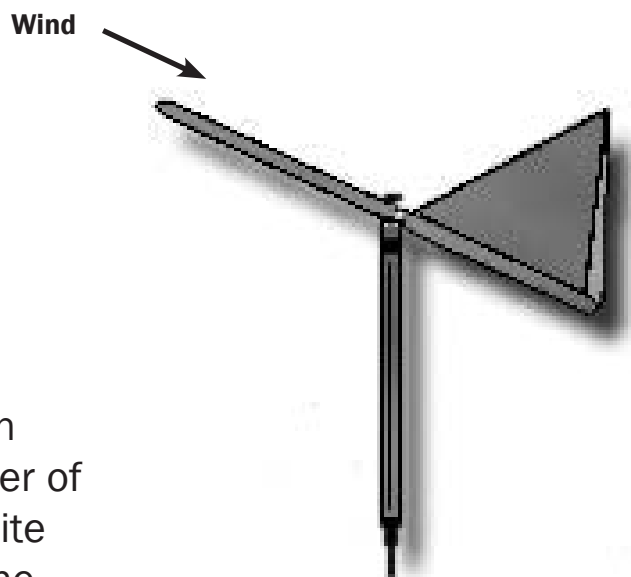



Wind Instrument Construction

Wind Vane

Before You Start

A weather vane is also called a wind vane. It is a tool for measuring wind direction. It spins on a rod and **points in the direction from which the wind comes**.

The weather vane is one of the oldest weather tools. The part of the vane that turns into the wind is usually shaped like an arrow. The other end is wide so it will catch the smallest breeze. The breeze turns the arrow until it catches both sides of the wide end equally. The arrow always points into the wind, telling you the direction from which the wind is coming. If the wind is blowing from the south, the wind is usually warm. If the wind is blowing from the north, the wind is usually cooler. The breeze turns the arrow on the weather vane until it catches both sides of the wide end equally.

Materials:

- Paper and pencil
- Scissors
- Cardboard
- Compass
- Plastic soft drink bottle
- Plastic drinking straw
- Shallow pan filled with rocks
- Felt-tipped marking pen

Arrow points into the wind

Wind →

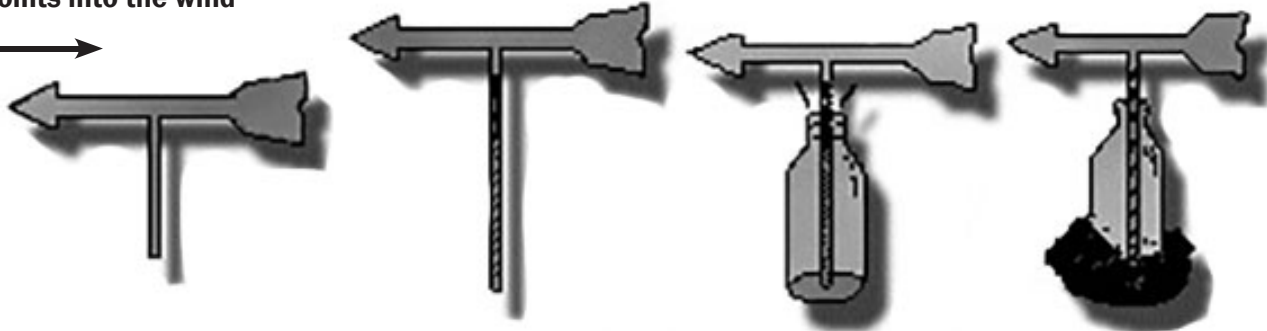

Procedure

Ask students what a weather vane is, and where they have seen weather vanes. Write down their answers. Ask them to draw a picture of a weather vane.

Have students carefully cut an arrow with a tab from the cardboard, as shown. If the end opposite the arrow is longer and wider than the arrow, it will work better. Remind students that scissors are sharp, so they must handle them carefully. Have them bend



Wind Instrument Construction

the tab slightly so the arrow turns easily when you put it in one end of the straw. They can put the other end of the straw in the bottle. Have them remove enough rocks from the pan to make room for the bottle and pile the rocks back around the bottle so it won't be blown over. (See illustrations above.)

A compass always points north. Have students use their compass (or schoolyard landmark) to find north, and then mark the four sides of the bottle E, W, N, and S with a felt-tipped pen.

Have students set their wind vane in a high place such as the top of a playhouse or a slide. Make sure that it does not wobble or tilt and that it is unobstructed so it can catch the slightest breeze.

Have them watch their weather vanes closely and then describe how they work. Test them on windy days and again when there is just a light breeze.

Background Information

A weather vane is a tool used to tell which direction the wind is coming from (many people mistakenly think the vane points in the direction the wind is going). This information can be useful in a number of ways; for example, early explorers needed to know what direction the wind was coming from to sail their ships, which helped them sail to America. Weather vanes are usually found on top of buildings so they will catch an open breeze. Look for them on top of barns, houses, weather stations, hardware stores, and other places that sell or use weather tools. The part of the vane that turns into the wind is usually shaped like an arrow. The other end is wide so it will catch the smallest breeze. Sometimes a metal rooster or other animal sits on top of the weather vane.

Some weather vanes have directional strips underneath the arrow to make it easier to read. Your markings on the bottle do the same thing.

It is easier to see how the energy from the wind moves your weather vane if it is up high and in an open area. You might also want to experiment by putting it on the ground.

Although a weather vane is one of the oldest weather tools, it is still used today to measure the direction of the wind. Weather vanes can only measure wind direction a few yards (meters) off the ground. Large, helium-filled weather balloons are used to measure winds high above Earth's surface. The balloons move with the same speed and in the same direction as the wind.